

Volume 37 Issue 4

April 2006

the PINNACLE

The Official Journal of the 495th R/C Squadron, Inc - Our 34th Year!

Pursuing R/C Excellence. Everyday.

AMA CHARTER #340

www.495thsquadron.org

Gold Leader Club!

April Meeting

View from the Left Seat

Insiders View

RC Tales

Gadget Corner

MASSACHUSETTS

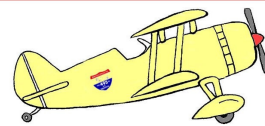

THE 495TH
R/C
SQUADRON

AMA CHARTER #340 THE 495TH R/C SQUADRON, INC. Since 1972!

the PINNACLE

Post Office Box 426
Tewksbury Mass 01876-0426
www.495thsquadron.org



March 2006 The PINNACLE Newsletter Volume 37 Issue 3

Contact us at: 495thrcboard@yahoo.com or write c/o address above:

Dick Adams	- Director	Paul Gosselin	- Secretary
Al Kinnon	- Treasurer	John Morely	- President
Jim Thompson	- Director	Rick Breton	- Director
Chris Rines	- Vice President	Steve Jackson	- Chief Instructor

'06 Groton Field Marshal - George Werber

'06 Pinnacle Street Field Marshal - Rick Breton

Newsletter Staff Editor - Paul Howard

Newsletter Associates - Roy P. Arsenault, Tony DiFinizio

Internet Specialist & '06 Webmaster - John Morley

495th R/C Squadron

April

SAFETY: EVERY MEMBER is RESPONSIBLE

www.495thsquadron.org/Fields.htm

Rules and Operational Procedures for both of our premier flying sites located in Groton and Tewksbury, Massachusetts!

Meeting Announcement

At the April 5th Club meeting, fellow member Art Alfano will host his annual *invitation only* Scale Show. As many of you know, Art's annual Scale Show has become one of the area's "must see" events, so be sure to mark your calendars for April 5th. This year, the fun begins at 6:30 PM. Coffee and refreshments will be served, and we will have a raffle.

May Meeting Announcement

At the May 3rd Club meeting, the Club will host a winter project show-n-tell night. Please bring your winter projects and show them off to your fellow Club members!

View From The Left Seat™

By

John Morley, President, The 495th R/C Squadron, Inc.

Well, the Winter season is finally coming to an end! I hope that everyone in the Club had an opportunity to build at least one new model airplane for the up-coming flying season. Personally, I have a brand new Gee Bee R2, a ¼ Scale Piper Cub, and a turbine powered trainer called the 'AV8R'. Clearly, I'm anxious for the nice weather to get here, so that I can maiden these new airplanes! I also look forward to going to the field this Spring and seeing all of your new projects!

As your President, I again want to reiterate that we are all responsible for operating in a safe and responsible manner at all times while at the two Club fields. This means that we must always abide by both the safety and the noise rules of the Club. As many of you know, we have had a number of noise complaints at the Pinnacle Street field in recent months. With the 2006 flying season upon us, I expect that this Spring we will be under more scrutiny than normal. The bottom line is that although our status with the State Hospital is currently secure, the Pinnacle Street field is ours to lose – an accident, or excessive noise could jeopardize our use of this wonderful resource. It is up to all of us to not only follow the rules, but to ensure that others do as well. Together, we can all work to ensure a safe and fun filled season of model aviation!

We have a number of exciting Club activities happening in the next few months. The first is the return of Art Alfano's Scale Show at the April 5th Club meeting. After deciding to discontinue the Scale Show, Art had a change of heart, and is at it once again! I have spoken to him a number of times, and this year's show promises to be bigger and better than ever!! The next Club event is the annual Spring Cleanup and Opening Day at Pinnacle Street on April 8th. Beginning at 10AM we will clean up the field, and the surrounding roadway. It is amazing how much trash accumulates during the Winter months, and this cleanup is our way of being a good neighbor to the Town of Tewksbury! Immediately following the cleanup will be a free barbeque lunch for all Club members. If you can make it, please bring a rake and an extra trash bag! Finally, Jim Thompson will host a Spring Fun-fly on May 6th. This event will be the first of many fun-fly's sponsored by the Club. Details will be available on the Club website shortly.

As I mentioned last month, a new Pin Pole is currently under construction. I have purchased all the raw materials, and they and the blue prints are currently at the welders awaiting assembly. I hope to have the finished product in my hands for paint and finishing by the 1st week in April. I have also purchased the materials to repair the damaged pilot stations. These should be complete and back at the field in the next few weeks.

Again, a reminder that each month the BOD will meet on the Thursday evening immediately preceding the regular Club meeting. Our meetings are held at the Jade East Restaurant, on Rt. 38 in Tewksbury, beginning at 7:30PM. There is plenty of room, and the atmosphere is informal, so we invite interested members to attend!

I'm looking forward to an exciting year in 2006, and I hope you see all of you at upcoming Club meetings, and at the field!

John Morley
President, The 495th R/C Squadron, Inc.

Mar. 23, 2006

INSIDER'S VIEW

Submitted by Roy Arsenault

Are we having fun yet?

The 495th RC squadron has a great amount of members with very diversified interests .They all have one very basic interest which seems to supercede all their other interests (o.k. after wine women and song).

We are talking radio control aircraft here, just so you don't get the wrong ideas. Now that we are thinking about the same subject ---let us continue, as a 495th RC squadron member you are in a very unique position.

"I am?" he replied meekly. " yes you are ----as a matter of fact, you have never had such an advantage in any other organization in your entire life". "Wow I am amazed, he smilingly conceded,"tell me more".

"OK, now pay attention".

You were born a baby? correct . At that young age you knew exactly nothing about aircraft.

Next came your formative years, grade school ,homework,high school, best friend relationships, family vacations together, first car,part time jobs and last but not least girls.

Yes, you really had a very busy early years history and by and large you weathered them rather nicely. All this resulted in your getting a good job ----met and married a nice girl and raised a family. There were a few bumps along the the way ---we all went there.

Now you've got all this behind you and you wonder to yourself; what's next ? You find life getting to be boring.

Sports gets your attention almost as a last resort,but there is still something lacking in your life .

One day you just happen to be driving by the field on pinnacle street in Tewksbury-----you are listening to your radio spouting rock and roll music.

As you proceed further along the road, you suddenly become aware of a bunch of cars parked by the side of the road ----you wonder (you do a lot of that lately) what is going on here? You decide to stop and look around after you notice several model aircrafts randomly located in different parts of the field . You also become aware of a buzzing in the air. Looking skyward you find the source of this buzzing to be two model planes performing aerobatic maneuvers in the sky .

you may not know it -but you are about to be smitten by the rc bug.

you stand there , almost hypnotized looking up at those two marvelously decorated ,gyrating ,swooping , diving ,spinning ,buzzing airplanes (you do have a way with words).

They are doing exactly what their pilot tells them to do via a remote control radio-----here it comes now.

One of the plane finally settles down to a slower normal flight and comes around the far end of the field -loosing altitude at the same time, till it's almost on the ground. Wide eyed and your mouth agape you stare at this phenomena till the wheels make contact with the ground .

The plane rolls past you for several yards as it slows down to a manageable ground speed --- then turns into the area not far from where you are standing . pow bang boom ---- you suddenly come out of your coma and realize that you must know more about this amazing hobby.

You have more than a million questions looking for answers.

Are you having fun yet ?

No but are about to change that all around. You are about to enter into what may be called the enlightenment zone. It is already happening -----

there is nothing you can do now to stop these urges that have taken over your mortal remains. Yes you are soon going to be experiencing the true meaning of "yes i am having fun"

-- happy landings ace !

RC Tails

By Roy P. Arsenault

chapter eight

As uncle Bruce's SUV pulled onto his ranch driveway , his attention was drawn to the corral, particularly he noticed, that there were fewer horses in the corral for that time of the day.

His wife Betty had been away in town most of the day and was still away on errands. They usually put the horses in the corral during the late afternoons as that was when the days hot temperatures started to cool down. The horses were also checked out and fed at this time.

"You guys go in the house " Bruce called to his companions." I'm going into the barn to check on the rest of the horses "

"We'll go with you uncle "said Terry.

After a thorough check of all the stalls , uncle Bruce determined that two of his best thoroughbred stallions were nowhere to be found.

Further searches throughout the ranch failed to produce the two missing stallions. Nothing else was found to be out of order or missing.

"looks like we have been robbed "claimed uncle Bruce."I'll notify the sheriff and we'll get an investigation started.

About this time Terry's aunt Betty arrived home. After a brief discussion concerning the current events she produced a full colored flyer that she had obtained in town." Terry you and Josh sure picked a fine time for your visit "she exclaimed ,next week the annual rodeo will be taking place at the rodeo grounds and it's always a lot of fun for everybody. I'm sure you both will enjoy the bull riding and all the other events that will take place there, plus this year they are having a horse race with a ten thousand dollar prize as you can see by the flyer that I have here. It should be a great time to get into the wild west spirit."

The next few days seemed to drag by as far as finding the two missing stallions. Terry and Josh spent most of their time flying RC planes in the range behind the barn.

Finally rodeo day arrived and both the boys got all dressed up in their finest western outfits, ten gallon hats , big belt buckles and cowboy boots completed their conversion from city boys to cowpokes.

Everyone from miles around turned out for this annual rodeo.the viewing stands were full of spectators. Everybody was cheering for their favorite riders in the bull riding contest.

In between the different events, to the surprise of both boys. a local RC model club put on several different demonstrations with RC cars , planes and helicopters for the enjoyment of the audience.

after watching the RC planes fly ,terry and josh made their way down to where the RC pilot was and introduced themselves. they soon had a great conversation ongoing and developed a very good rapport with the RC pilot. It seems like they all had similar interests in RC planes.

Terry invited the RC pilot, Jerry to his uncles ranch for more RC flying after the rodeo ended.

A western rodeo is not a one day affair ,they go on for several days.

during this time the three boys got to become great friends.

For the next few days that the rodeo was in town, Terry and Josh spent most of their time behind the scenes with their new found friend,Jerry.

They even assisted Jerry with some of the RC demonstrations.

Finally the last day of the rodeo arrived. This was the day of the big \$ 10,000 dollar horse race. A list of the horses and riders was posted which showed that there would be fifteen horses running in this race.

It had been a great fun week -----with the big race coming -----this would put a thrilling finally to all the fun times they had enjoyed.

After the last contest event ended, a final RC plane demonstration was enjoyed. While the big race was set up,everybody in the viewing stands was standing and cheering as the horses and riders took their positions at the starting line. the race was to be one mille long going outside of the rodeo grounds.

The RC demo finished in grand style. Terry and Josh helped Jerry to gather his RC gear, "hey guys, " said Jerry "leave the RC gear where it is and let's watch the start of the big race,wow look at all those beautiful horses all lined up in a row and raring to go." Bang -----with the echo of the starter's pistol ringing in their ears -----the big race was on. In a huge cloud of dust, fifteen horses and riders sprang into action.-----making a right turn out of the rodeo ground's gate onto the outside perimeter of the area. It was hard to tell who was leading as they made their exit. They were pretty well bunched up heading down the outside road.

For the passed hour ,black clouds had been forming over the area. Rain squalls it seemed, were in the offing, but for now all eyes were on the big race. everyone seemed to have a favorite. Binoculars were put to good use following the fast moving group, which was showing signs of stretching out as the race progressed. At the halfway point, three riders seemed to be pulling away from from the rest of the bunch, but they were all giving it their best shots.

Deep rumbles and flashes of lightning were starting to echo nearby and getting closer and closer, and a few drops of rain were beginning to fall.

Heading down the home stretch the three leaders were leaving the remaining dozen other riders behind.

Coming around the turn into the rodeo grounds, a huge bolt of lightning suddenly lit up the entire sky for a split second ----. Followed by a long and loud clap of thunder which caused one of the three lead horses to break his stride ---rear up on his hind legs --throw his rider and race off in another direction.

This left the other two riders so far in the lead that the only question now was who would be the big winner of the ten thousand dollars?

(to be continued in chapter nine next month)

Gadget Corner

by Tony DiFinizio

Let me start by introducing (or reintroducing) myself. My name is Tony and this is my first season as an RC pilot. I got my solo over the summer of 2005. I wrote one article in a newsletter in the fall. I am a mechanical engineer by trade and, like all men, I love gadgets, tools and toys. That's one of the main reasons why I started this hobby. It can be as much fun to build the planes as it is to fly them. (But sadly not as much fun to rebuild a crashed plane)

This is the first installment of Gadget Corner and hopefully I will write one almost every month. My plan is to document my experience with a new gadget or tool. A lot of tools are new to me as I am just starting out. Hopefully you can learn from what I learn as I get more involved in the hobby. We'll see how this goes. Feel free to email me with comments about the Gadget Corner and ideas about future articles.

My first topic is near and dear to most of us who like to build kits and even some ARFs: Hinge Slots. Many planes use Sig Easy Hinges or what Great Planes just calls CA hinges. They are a laminated plastic piece that is very flexible and has pores to absorb CA glue and wick it down into a slot cut in balsa parts.



Hinges

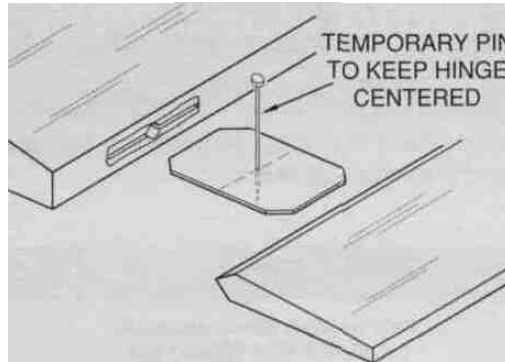

Hinges ready to be installed

These hinges are pretty easy to use and seem durable. The less-than-fun part of these hinges is cutting the hinge slots. Ideally they should be nice thin slots a bit thicker than the hinge material. That way thin CA glue will wick into the slot and adhere the hinge to the wood. If you make big sloppy hinge slots then you have more chance of poor adhesion and a weak joint.

The first method is to use a #11 hobby knife. This is the “old school” way to do it and the way its been done for years.

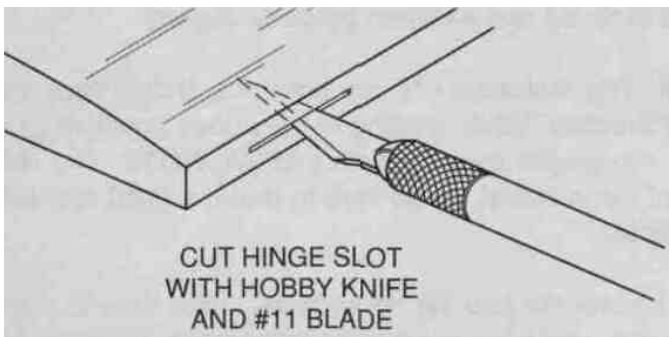

Simply scribe a line at the center of the trailing edge or fin or aileron or whatever and mark the location of where you want the slot. Then take a hobby knife and work it in. You aren't really cutting away material but compressing the wood to make the slot. You have to use a new blade and change it often. This method works OK but has a high risk of 1) slicing your hand open 2) making a nasty looking hinge slot 3) having the knife go in at an angle and rip open the part. I only tried this once and gave up. Call me a baby or a techno weenie but there has to be a better way! I rate this method as “lousy”.

Sure enough wherever you find a difficult task or something that is a pain in the butt, there is usually somebody else with a solution or solutions. Remember, if it weren't for lazy engineers you would not have a TV remote!

Enter the second method, the hinge-slotting tool. These are made by several manufacturers. I tried the Du-bro model although it looks almost the same as the GP version.



The idea is to install the “V” shaped tool into a hobby knife handle and use it to make the slot. The tool comes in several widths and thicknesses for various size hinges. This one comes with a clever tool to center the slot. You place the tool (on the far left side in the photo) on the wooden part and squeeze it together. The scissor action places the central piece exactly in the middle of the edge so you get the slot in the center without making a mark. It also helps the blade go in perpendicular to the fin. You have to work the V tool back and forth while pushing it in to make the slot.

That’s the fun easy part. It looks like you just made a nice clean, thin, even slot. Remember what I said about the knife method though. The slot isn’t really “cut” into the wood, the wood has been pushed around to make the slot. With the V tool the excess material is pushed into the center of the hinge slot. You need to use the “picker tool” shown on the far right side to pick the scrap bits of balsa out of the hinge slot.

After making one plane with this method I got pretty good at it. I had to practice a bit on scrap wood before making my first attempts. (Note to you guys, always practice this stuff on scrap wood first!) My first slots looked horrible. I caused more damage with the picker tool than the hobby knife in method 1. It’s easy to get carried away and mess up the slot. I also accidentally pushed too hard and ripped the wooden part open by angling the picker upwards and destroyed a rudder. Luckily it was an easy part to fab from 1/4” balsa. I rate this method as “OK”. Its about \$4 bucks so what the heck. If it works a few times it pays for itself.

OK now for the final method. Anything that can be done by hand can be done better with a power tool right!? Of course!

Great Planes has a power tool for the job called the “Slot Machine”. Kinda catchy eh? This is a small hand held power tool that has two flat blades that are placed back to back. They move back and forth like a scroll saw blade to chew open a slot.



Once again you mark a center line and the location of the slot. Then hold the Slot Machine up to the wood and press the go button. The blades dig right in and make a nice clean slot with no need to pick anything out of it. Voila, done in 1.5 seconds. Ok that's the end of the commercial for the Slot Machine.

In reality there are some issues. The first is that when you start to just cut into the wood the tool grabs and will often jump and not make the slot where you wanted it. To remedy this they created a guide tool shown below.



This is pretty self explanatory. It has little screws so you can adjust the location of the slot and then you just hold it tightly to the wood and insert the blades into the guide slot. This keeps the blades from grabbing and helps guide the tool in straight. The Slot Machine is \$20 and the guide is \$4 bucks. Not too bad. If you make a few kits this will save you a lot of time and it really does make nice clean slots. They have blades of different thicknesses for other hinges.

I must say that the Slot Machine I bought was defective out of the box. I made a few practice cuts and then it just stopped working. I could hear grinding gears inside and the blades refused to move. I removed the cover plate and could see a plastic worm gear spinning away, stripped out. I called the number in the manual and spoke directly to Great Planes. They sent me a new one without asking and a week later I was back in business. I give the Slot Machine a score of "Pretty Awesome" for hinge slot quality, a "kind of cheap" for build quality and "Excellent" for customer service.

The final method of choice is up to you. Are you an old school kind of guy who wants to do it the old-fashioned way, or do you want it to be easier? Is \$4 bucks too much to spend on a tool or is \$25 worth spending to make better slots?

I hope you learned something, I know I did!

PLEASE PATRONIZE our LOCAL R/C Suppliers!
(Raffle Items regularly purchased from list below)

Bill's Hobby Barn

326F South Broadway
Salem, NH 03079
Phone: 603-898-9241

Bob Rheault

Weekend Supplier of small parts
Methuen, MA
Phone: 978-683-4250

RC Buyer's Warehouse

95 Northeastern Blvd.

Nashua, NH 03062 Phone: 603-595-2494 Fax: 603-595-2559